



Product information presented here reflects conditions at time of publication. Consult factory regarding discrepancies or inconsistencies.

ENGINEERED PRODUCTS

Zoeller Family of Water Solutions™

MAIL TO: P.O. BOX 16347 • Louisville, KY 40256-0347
 SHIP TO: 3649 Cane Run Road • Louisville, KY 40211-1961
 (502) 778-2731 • 1 (800) 928-PUMP • FAX (502) 774-3624

visit our web site:
www.zoeller.com



Tested to UL Standard UL778.



Certified to CSA Standard C22.2 No.108.



**PERFORMANCE DATA COMMERCIAL EFFLUENT PUMPS
 MODELS 6185, 6186, 6188, 6189**

GENERAL DATA

	<input type="checkbox"/> 6185	<input type="checkbox"/> 6186	<input type="checkbox"/> 6188	<input type="checkbox"/> 6189
PUMP NAME PLATE HORSEPOWER:	1 HP	1.5 HP	1.5 HP	2 HP
SOLID SIZE: in (mm)	¾" (19mm)	¾" (19mm)	¾" (19mm)	¾" (19mm)
MINIMUM HEAD: ft. (m)	30.0' (9.1m)	5.0' (1.5m)	5.0' (1.5m)	5.0' (1.5m)
MAXIMUM HEAD: ft. (m)	73' (22.3m)	114' (34.7m)	91' (27.7m)	110' (33.5m)
MAX.FLOW GPM (L/min) @ MIN. HEAD ft. (m)	85 GPM @ 30'	58 GPM @ 5'	145 GPM @ 5'	145 GPM @ 5'
DISCHARGE SIZE: VERTICAL FEMALE	(322 L/min @ 9.1m)	(229 L/min @ 1.5m)	(549 L/min @ 1.5m)	(549 L/min @ 1.5m)
	<input type="checkbox"/> 1½" <input type="checkbox"/> 2" <input type="checkbox"/> 3" NPT	<input type="checkbox"/> 1½" <input type="checkbox"/> 2" <input type="checkbox"/> 3" NPT	<input type="checkbox"/> 1½" <input type="checkbox"/> 2" <input type="checkbox"/> 3" NPT	<input type="checkbox"/> 1½" <input type="checkbox"/> 2" <input type="checkbox"/> 3" NPT

PUMP NET WEIGHT: lbs (kg)	89-94 lbs (40-43 kg)	MOTOR TYPE:	SUBMERSIBLE
SERVICE FACTOR:	1.15	TYPE SOW POWER CORD LENGTH: ft (m)	25' (7.62m) <input type="checkbox"/> _____'
MOTOR DESIGN LETTER:	NEMA B	MOTOR SHAFT:	416 S.S.
IMPELLER TYPE:	BRONZE VORTEX	STATOR AND LEAD WIRES INSULATION:	6185 CLASS B
O-RINGS AND COVER GASKET:	VITON		6186 - 6189 CLASS F
RPM:	3450	MAXIMUM STATOR TEMPERATURE:	CLASS B 266°F (130°C)
			CLASS F 311°F (155°C)

SHAFT SEAL CONSTRUCTION:	STANDARD	UPPER-CARBON/CERAMIC, LOWER-SILICON CARBIDE/ CARBON
	OPTIONAL <input type="checkbox"/> UPPER <input type="checkbox"/> LOWER	<input type="checkbox"/> SILICON CARBIDE / CARBON <input type="checkbox"/> SILICON CARBIDE / SILICON CARBIDE <input type="checkbox"/> SILICON CARBIDE / SILICON CARBIDE
MOTOR THERMAL SHUTOFF:	STANDARD (Single Phase Only)	THERMAL OVERLOAD WITH AUTOMATIC RESET
MOISTURE DETECTION:	<input type="checkbox"/> OPTIONAL*	MOISTURE SENSING PROBES
MINIMUM RECOMMENDED FLUID LEVEL: in (m)		10" (0.25m)
MAXIMUM WATER TEMPERATURE:		130°F (54°C) 120°F (49°C) FOR WD6189

*Requires a circuit in control panel to function.
 **See back side for listed UL and CSA models.

MODEL	HP	200-208V/1PH		<input type="checkbox"/> 230V/1PH		<input type="checkbox"/> 200-208V/3PH		<input type="checkbox"/> 230V/3PH		<input type="checkbox"/> 460V/3PH		<input type="checkbox"/> 575V/3PH	
		FLA	LRA	FLA	LRA	FLA	LRA	FLA	LRA	FLA	LRA	FLA	LRA
<input type="checkbox"/> 6185	1	11.5	26.9	9.8	19	7.5	30	7.4	27	3.7	14	3.3	12
<input type="checkbox"/> 6186	1½	17.2	48.3	13.7	38	10.3	42	9.2	35	4.6	18	3.6	18
<input type="checkbox"/> 6188	1½	16.8	48.3	14.0	38	10.3	42	8.9	35	4.6	18	3.5	18
<input type="checkbox"/> 6189	2	20.5	48.3	17.1	38	13.2	42	11.2	35	6.0	18	5.8	18

Refer to reverse side for Head/Capacity Performance Curves

Double Seal-6180 Series
Weight 89-94 lbs.

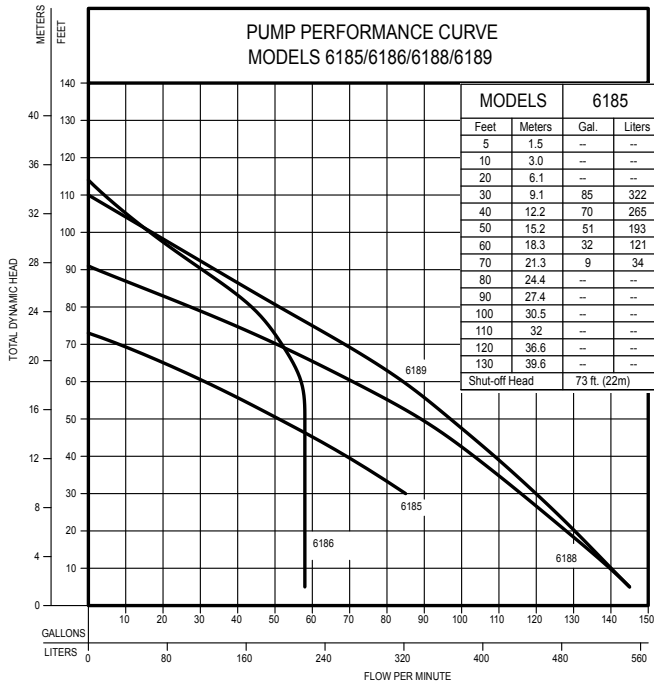

MODELS		6185		6186		6188		6189	
Feet	Meters	Gal.	Liters	Gal.	Liters	Gal.	Liters	Gal.	Liters
5	1.5	--	--	58	220	145	549	145	549
10	3.0	--	--	58	220	140	530	140	530
20	6.1	--	--	58	220	128	484	130.5	494
30	9.1	85	322	58	220	116	439	120	454
40	12.2	70	265	58	220	103.5	392	109	413
50	15.2	51	193	58	220	90	341	97	367
60	18.3	32	121	58	220	71	269	85	322
70	21.3	9	34	52	197	51	193	69	261
80	24.4	--	--	45	170	28	106	51	193
90	27.4	--	--	30.5	115	2	8	34	129
100	30.5	--	--	16	60	--	--	17	64
110	32	--	--	4	15	--	--	--	--
120	36.6	--	--	--	--	--	--	--	--
130	39.6	--	--	--	--	--	--	--	--
Shut-off Head		73 ft. (22m)		114 ft. (35m)		91 ft. (28m)		110 ft. (34m)	

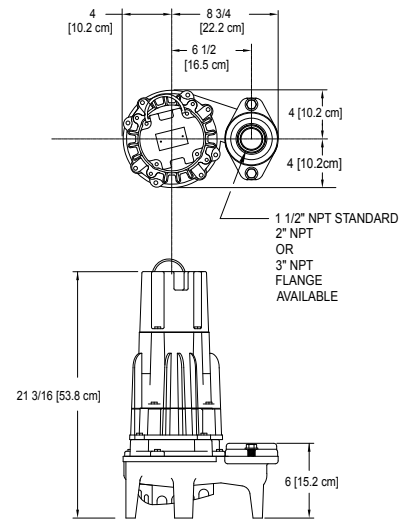

SK1413

CAUTION Model 6185 should not be operated below 30' TDH

Standard all models - 25 ft. cord - 1 HP

6185 MODELS	Control Selection (See Selection Guide)					Listings	
	Volts	PH	Amps	Simplex	Duplex	UL	c CSA us
*E6185	230	1	9.8	1,2 or 3	4	Yes	Yes
I6185	200	1	11.5	2 or 3	4	No	No
J6185	200	3	7.5	3	4	Yes	Yes
F6185	230	3	7.4	3	4	Yes	Yes
G6185	460	3	3.7	3	4	Yes	Yes
BA6185	575	3	3.3	3	4	Yes	Yes

Standard all models - 25 ft. cord - 1.5 HP

6186 MODELS	Control Selection (See Selection Guide)					Listings	
	Volts	PH	Amps	Simplex	Duplex	UL	c CSA us
*E6186	230	1	13.7	2 or 3	4	No	Yes
I6186	200	1	17.2	2 or 3	4	No	Yes
J6186	200	3	10.3	3	4	No	Yes
F6186	230	3	9.2	3	4	No	Yes
G6186	460	3	4.6	3	4	No	Yes
BA6186	575	3	3.6	3	4	No	Yes

Standard all models - 25 ft. cord - 1.5 HP

6188 MODELS	Control Selection (See Selection Guide)					Listings	
	Volts	PH	Amps	Simplex	Duplex	UL	c CSA us
*E6188	230	1	14.0	2 or 3	4	Yes	Yes
I6188	200	1	16.8	2 or 3	4	No	Yes
J6188	200	3	10.3	3	4	Yes	Yes
F6188	230	3	8.9	3	4	Yes	Yes
G6188	460	3	4.6	3	4	Yes	Yes
BA6188	575	3	3.5	3	4	No	Yes

Standard all models - 25 ft. cord - 2 HP

6189 MODELS	Control Selection (See Selection Guide)					Listings	
	Volts	PH	Amps	Simplex	Duplex	UL	c CSA us
*E6189 ⁽³⁾	230	1	17.1	2 or 3	4	Yes	Yes
*WD6189 ⁽³⁾	230	1	17.1	---	---	No	No
I6189	200	1	20.5	3	4	No	Yes
J6189	200	3	13.2	3	4	Yes	Yes
F6189	230	3	11.2	3	4	Yes	Yes
G6189	460	3	6.0	3	4	Yes	Yes
BA6189	575	3	5.8	3	4	No	Yes

* Molded Plug
 ** Double Seal pumps are available with optional moisture sensors. Seal Fail indicator light available in NEMA 4X control panels.
 (3) 20 Amp Outlet, P/N 10-0060 must be used.

FEATURES

- Durable Epoxy Coated cast iron construction
- Motor - 1 HP - 2 HP, 60 Hz, 3450 RPM, 1 PH or 3 PH, oil-filled, hermetically sealed, automatic reset, thermal overload protected (1 PH)
- Bearings - Upper and lower ball bearings
- Stainless Steel Motor Shaft
- Dual Mechanical Shaft Seals - Upper carbon/ceramic, Lower silicon carbide/carbon. Optional seal materials available
- Viton O-ring seals and cover gasket
- Impeller - Non-clogging bronze vortex design passes 3/4" spherical solids
- 25 foot UL Listed 3 wire neoprene cord and plug. Longer cords available in lengths of 35-50 feet
- No screens to clog
- Stainless steel screws, bolts and handle
- 1 1/2" NPT discharge with 2" or 3" flange available
- Corrosion resistant powder coated epoxy finish

- Moisture sensors available for early warning of seal failure. (Optional)
- 100% computerized tested.

SELECTION GUIDE

1. Single or Double piggyback variable level float switch pump control using the 15 amp plug and receptacle. Refer to ZM1536.
2. Single piggyback variable level float switch, hard wiring the pump lead wires to the float switch leads.
3. Refer to ZM1342 and select the correct simplex control panel listed for the pump. Refer to ZM1536 and select the desired variable level control switch, 3 required.
4. Refer to ZM1342 and select the correct duplex control panel listed for the pump. Refer to ZM1536 and select the desired variable level control switch, 3 or 4 required.

For additional information on Zoeller products refer to catalog for; Rail Systems, ZM1347; Float Switch Brackets, ZM1328; Check Valves, ZM1348; High Water Alarm Panels and Float Switches, ZM1536; Control Panels, ZM1342.

CAUTION

All installation of controls, protection devices and wiring should be done by a qualified licensed electrician. All electrical and safety codes should be followed including the most recent National Electric Code (NEC) and the Occupational Safety and Health Act (OSHA).